



AP-5DA15260AU 52cm Fan Module

Features & Benefits

Easy Cleaning

Stainless steel finish for easy cleaning. Grease filters are dishwasher safe for easy cleaning.

Vision Comfort

Neutral colour lighting with wide downward illumination help with creating a perfect cooking experience.

Controls

Soft button controls located on the base of the appliance.

Stylish

Fully integrated for maximum, stylish kitchen presentation.

Programs

Extraction mode with 3 power levels
Recirculation mode (requires carbon filter)

Energy Source

Electric

Specification

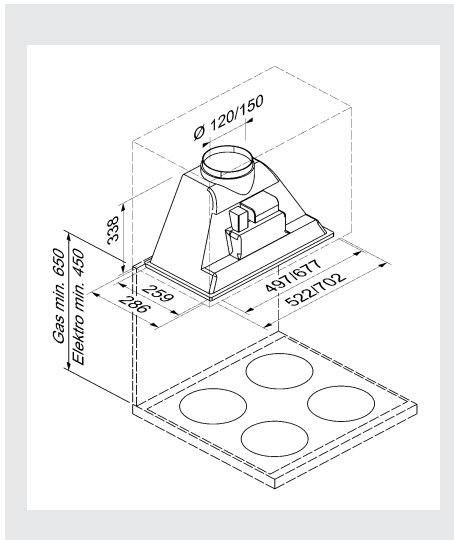

Dimensions

Appliance:
H337.5 x W522 x D286mm

Material

Grease filter: Aluminium
Surface: Stainless Steel

Finish

Black steel

Grease Filter

Dishwasher safe: Yes
Odour filter: Optional

Weight

Net: 4.4kg

Type

Built-in

Control

Push button

Lighting

4W LED lamps x 2
Temperature: 4,000K
Illuminance: 100 lux

Extraction

Direction: Upward
Power: 250-590m³/h

Noise

Minimum: 47dB
Maximum: 63dB

Connection

- Voltage: 220-240 V
- Total connected load: 160 W
- Frequency: 50 Hz
- Installation: Built-in
- Energy Source: Electric
- Approval certificates: RCM
- Required distance from induction hob: 450mm
- Required distance from gas hob: 650mm
- Appliance dimensions: 337.5 x 522 x 286 mm
- Packaging dimension: 425 x 605 x 365 mm
- Exhaust air outlet area: 150/120mm
- Height of the unit without chimney: 337.5mm
- Length of connection cable: 150cm
- Connection type: Australian
- Position of fan: Motor in the housing
- Housing material: Plastic
- Flow direction: Upwards
- Maximum sound power: 63dB
- Number of lamps: 2 LED lamps
- Total power of lamps: 8W

Accessories

