



AP-5BC93190AU 90cm Built-in Oven

Features & Benefits

Easy Cleaning

Removable door, enamelled smooth oven walls and suspended grills for easy cleaning.

Heat Trap

Full glass inner door combined with an internal oven light for viewing so there is no need to open the door, releasing the heat.

Quick Heating

Enamelled cooking chamber for faster oven heating.

Energy Efficient

Energy efficiency class A. 220-240 V with a total connected load 2.8kW.

Child Safe

Triple glazed glass creates a low door temperature which prevents serious burns from accidental contact.

9 Functions

Defrost	Double grill
Fan force convection	Grill
Convection	Bottom heat
Fan force grill	ECO
Rotisserie	

Display and Controls

3 dial knobs for control and LED indicators for activity and warning.

Heating

Electric

Timer

Off, On, Alarm

Specification

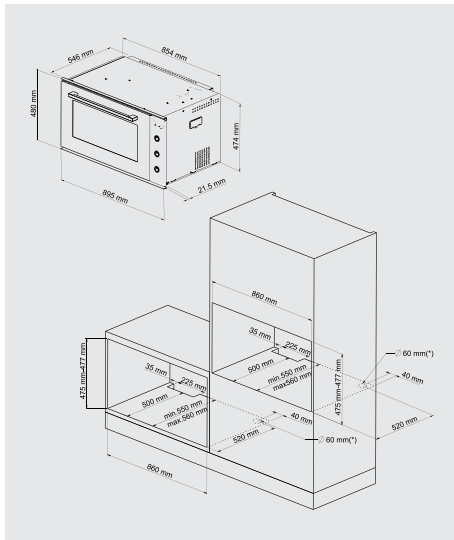

Dimensions

Appliance:
H⁹⁰⁰ x W⁵⁴⁵ x D⁴⁸⁰mm
Installation:
H⁴⁷⁷ x W⁸⁶⁰ x D⁵²⁰mm

Screen Height

-

Weight

Net: 48 kg

Volume

Net: 93 litres

Type

Built-in

Material

Door: Glass
Panel: Stainless Steel
Oven walls: Enamel

Finish

Stainless Steel & Black

Built-in Lights

1

Connection

- Energy consumption conventional heating - oven 1: 1.06 kWh
- Energy consumption convection/hot air - oven 1: 0.69 kWh
- Hedging: 12.2 A at 230V
- Voltage: 220-240 V
- Frequency: 50/60 Hz
- Plug type: no plug
- Front color: glass
- Energy source: Electric
- Approval certificates: CE, CB
- Length of power cable: 100 cm
- Net weight: 48.0 kg
- Gross weight: 56.0 kg

Accessories



Combination grate



Enameled baking tray