



AP-5DD72555 90cm Ceiling Hood

Features & Benefits

Easy Cleaning

Stainless steel finish makes it easy to wipe off food splatters. Grease filters are dishwasher safe for quick cleaning.

Vision Comfort

Lighting power and colour can be adjusted with wide downward illumination to create a comfortable work station of preference.

Hearing Comfort

Maximum noise level as loud as average human conversation; provides powerful extraction without too much noise inconvenience.

Multi Control

Extractor fan links with hob for adjustment using the hob's control panel. Automatically turns on when hob is switched on; conversely turns off when hob is not in use with an option to delay to absorb all vapours still present after cooking.

Stylish

The appliance is integrated to the kitchen, making it more elegant.

Energy Efficient

Class A+ efficiency with average yearly consumption of 38.3kWh.

Programs

Extraction mode with 3 power levels
Recirculation mode (requires carbon filter)

Energy Source

Electricity

Specification

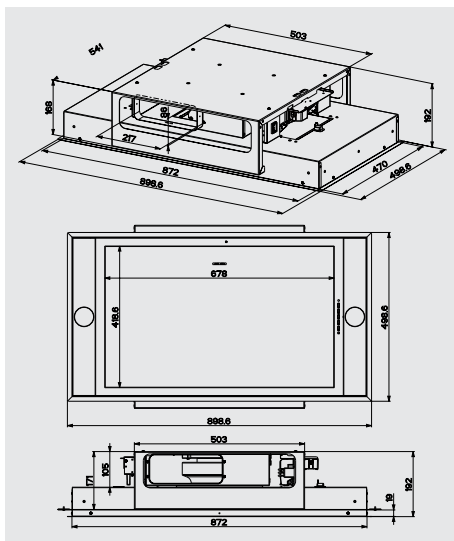

Dimensions

Appliance:
H192 x W899 x D499mm

Material

Grease filter: Aluminium
Surface: Stainless Steel

Finish

Stainless steel

Grease Filter

Dishwasher safe: Yes
Type: Cassette
Odour filter: Optional

Weight

Net: 23.9kg

Type

Built-in

Control

Electronic control
Multi control

Lighting

2.7W LED lamps x 2
Temperature: 4,000K
Illuminance: 111 lux

Extraction

Direction: Upward
Power: 490-700m³/h

Noise

Minimum: 40dB
Maximum: 65dB

Connection

- Voltage: 220-240 V
- Total connected load: 150.4 W
- Frequency: 50 Hz
- Installation: Built-in
- Energy Source: Electric
- Gross weight: 30.2kg
- Approval certificates: CE
- Required distance from induction hob: 650mm
- Required distance from gas hob: 650mm
- Appliance dimensions: 192 x 899 x 499 mm
- Installation dimension: 421 x 1005 x 625 mm
- Exhaust pipe dimension: 217 x 86mm
- Length of connection cable: 120cm
- Connection type: Plug
- Position of fan: Motor in the casing
- Flow direction: Upwards, to the side
- Maximum sound power: 65dB
- Number of lamps: 2 LED lamps
- Total power of lamps: 5.4W

Accessories

