



AP-5IX99290AU

# 90cm Induction Cooktop with Integrated Extractor Fan

Cooktop Datasheet

## Features & Benefits

### Easy Cleaning

Frameless, flush installation to reduce cleaning surface. Glass top means a regular kitchen surface cleaner should be enough.

### Efficiency

Pot detection switching for less panel operation. Cooking zone booster for quick heating. Zone linking possible for a larger cooking zone.

### Cooking Assist

Timer and countdown function available.

### Stylish Design

Sleek glass look in black colour that suits any modern style.

### Space Saving

Flush installation integrates the surface for a wider workstation space. Slim and flat design requires less space for installation.

### Safety Feature

Child lock and residual heat indicators to avoid accidents. A safety switch off is available in case of emergency.

### Multiple Cooking Zones

4 zones that can be simultaneously used. Zone linking is possible between 2 adjacent zones.

### Display and Controls

Touch control panel and 7-segment digital LED display located in front. Electronic control in 10 power levels.

### Energy Source

Electricity

## Specification

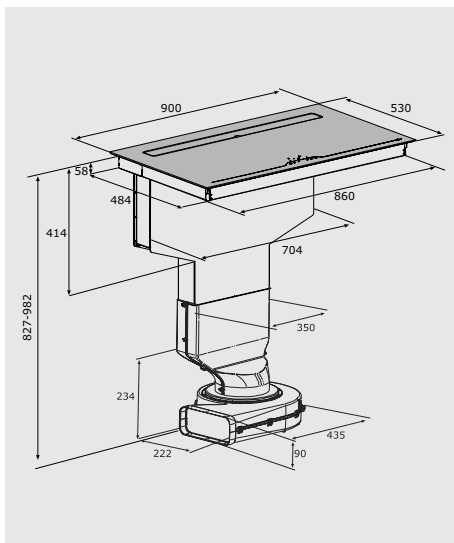

### Dimensions

Appliance:  
H827-982 x  
W900 x D530mm  
Installation:  
H58 x W862 x D495mm

### Material

Surface: Glass ceramic

### Weight

Net: 30.8kg

### Type

Built-in, frameless  
combi-induction

### Finish

Black

### Cooking Zone Power (+Booster)

4 zones Ø 22cm  
- 2.1 kW (3.7kW)

### Control

Touch control panel  
located in front  
Pot detection

### Display

LED display with 7  
segments  
Residual heat indicator

## Connection

- Voltage: 220-240 V
- Total connected load: 8 kW
- Frequency: 50/60 Hz
- Device color: Black
- Energy Source: Electric
- Approval certificates: CE, RCM
- Packaged unit dimensions:
- Niche dimensions:
- Device width: 900mm
- Dimensions of the device: 827-982 x 900 x 530 mm
- Length of connection cable: 150cm
- Plug type: without plug

## Accessories





AP-5IX99290AU

# 90cm Induction Cooktop with Integrated Extractor Fan

Extractor Fan Datasheet

## Features & Benefits

### Easy Cleaning

Glass surface means a regular kitchen surface cleaner should be enough. Removable water collection tank and dishwasher friendly grease trap for easy cleaning.

### Efficiency

Control panel is in front of the unit, no need to reach into the extractor fan to operate.

### Automation

Automatic overrun for circulation mode and 3-level overrun for 5/10/20 minutes. Blocks collection tank after 40 hours of operation.

### Stylish Design

Sleek glass look in black colour that suits any modern style. Downward suction frees up space above the cooktop for a minimalistic design.

### Space Saving

Compact design makes it suitable for installation in a kitchenette or kitchen island.

### Quiet but Powerful

Wide opening allows for huge amount of extraction without being too loud.

### Modes

Extraction  
Circulation (carbon filter required)

### Display and Controls

Touch control panel and 7-segment digital LED display located in front. Electronic control in 5 power levels plus 1 intensive level.

### Energy Source

Electricity

## Specification

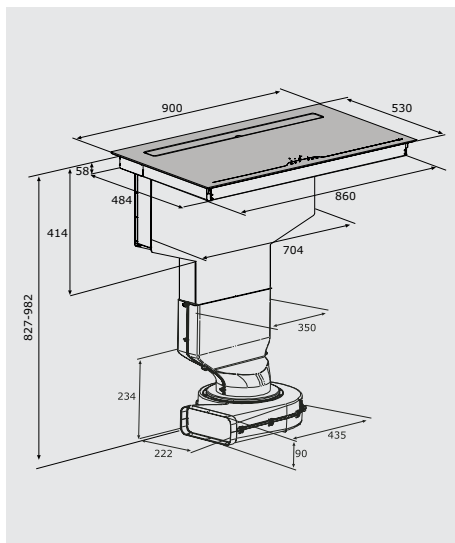

### Dimensions

Appliance:  
H827-982 x  
W900 x D530mm  
Installation:  
H58 x W8.2 x D495mm

### Material

Surface: Glass ceramic

### Weight

Net: 30.8kg

### Finish

Black

### Noise

Minimum: 45dB(A)  
Maximum: 65dB(A)  
Intensity: 70dB(A)

### Fan Output

Extraction: 580m<sup>3</sup>/h  
Circulation: 450m<sup>3</sup>/h

### Intensity Level

Extraction: 730m<sup>3</sup>/h  
Circulation: 560m<sup>3</sup>/h

### Grease Filter

Metal grease filter  
Efficiency: Class B

### Collection Tank

Capacity: 0.75L

### Display

LED display

### Extraction

Downward

## Connection

- Voltage: 220-240 V
- Total connected load: 0.165kW
- Frequency: 50/60 Hz
- Device color: Black
- Energy Source: Electric
- Approval certificates: CE, RCM
- Packaged unit dimensions:
- Niche dimensions:
- Device width: 900mm
- Dimensions of the device: 55 x 590 x 520 mm
- Length of connection cable: 150cm
- Plug type: without plug

## Accessories

